



Yuekchun Const. Co. Ltd
 TEL +82 22691 6000
 FAX +82 22691 6001
 Web : y6000.co.kr
 E - mail1 : yccglobal@gmail.com
 E - mail2 : y6000@paran.com

PEINER SK 575

Hammerhead Tower Crane
 35,200-70,500 lbs. (16-32 t)
 Lifting Capacity

SPECIFICATIONS

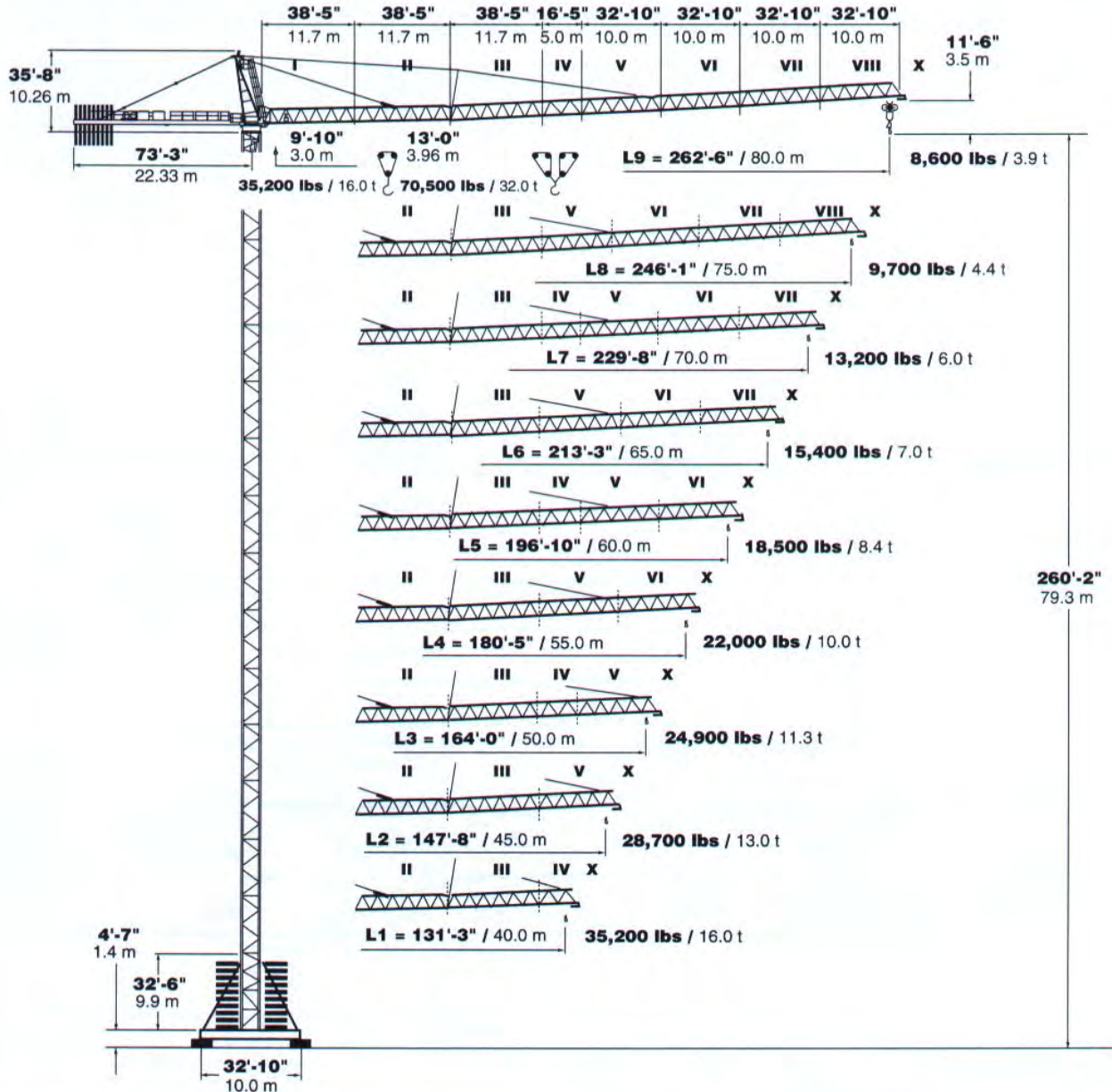

simple, available and
cost effective™



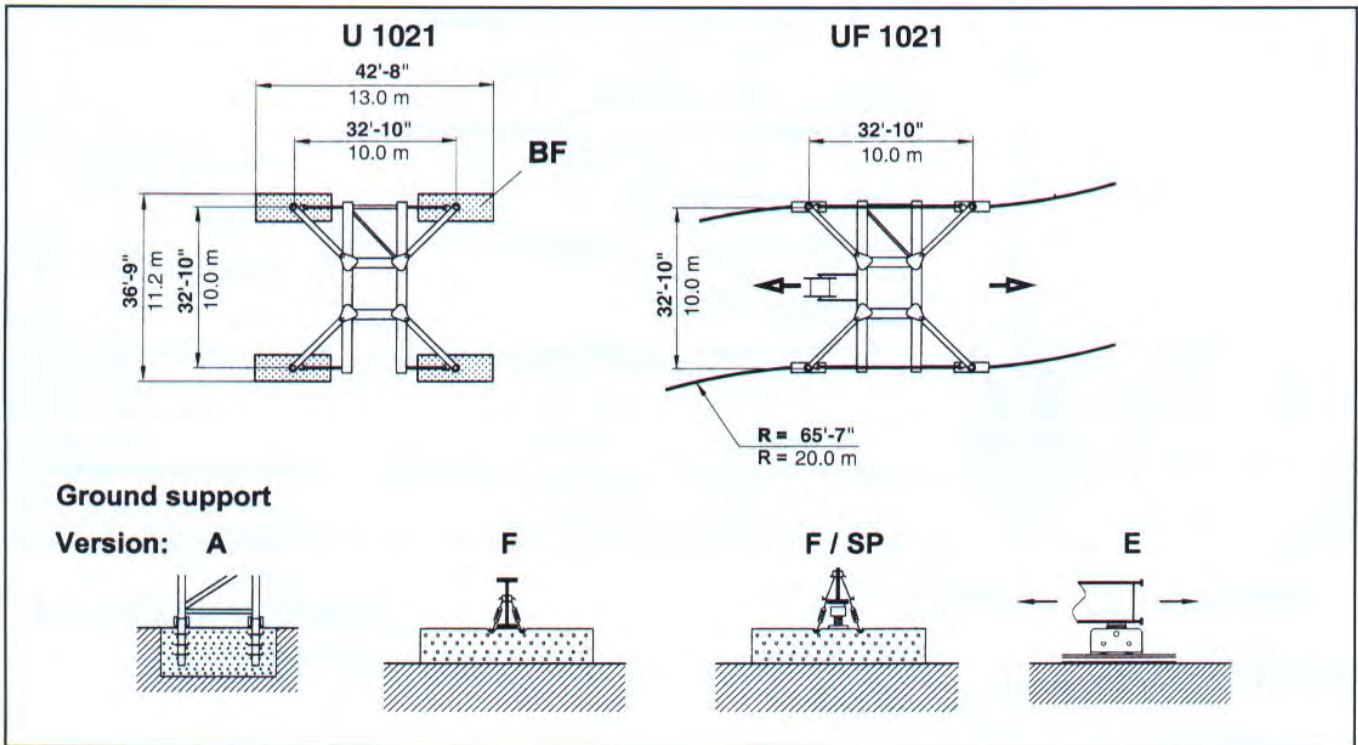
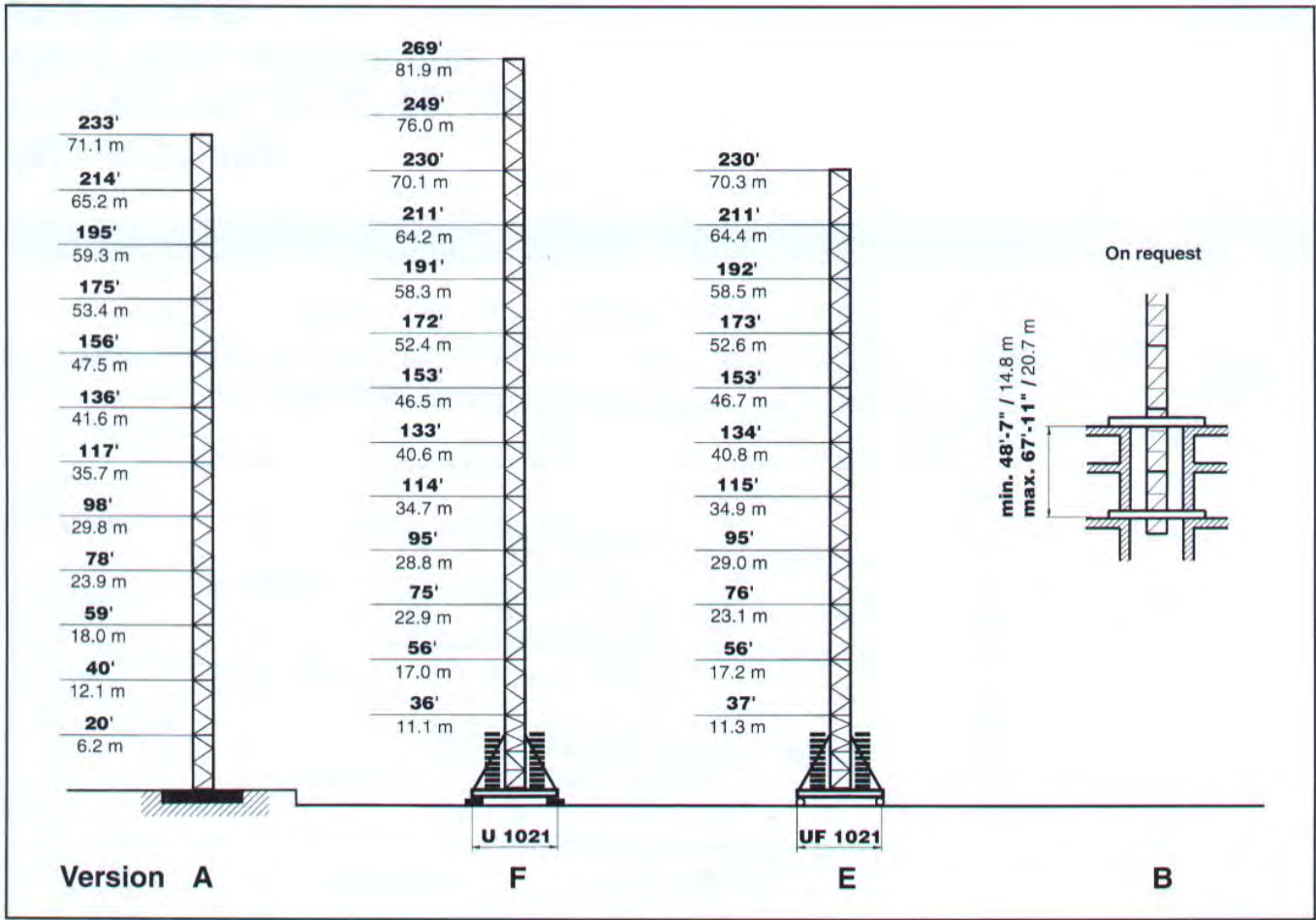

Machines shown may have optional equipment.

PEINER SK 575

Combinations of tower section, tower heights, base ballast















PEINER SK 575 Radius and Capacity

Jib	Max Capacity from		Radius																	
			ft/m	4-Part line max. 70,500 lbs. max 32.0 t								 / 		2-Part line max. 35,200 lbs. max. 16.0 t		Radius - 3'-4"/1.0 m Capacity - 3086 kips/1.41 t				
	ft. m	9'-10" to 3.0 m to	13'-0" to 3.96 m to	45'-11" 14.0	52'-6" 16.0	59'-1" 18.0	65'-7" 20.0	76'-9" 24.0	91'-10" 28.0	98'-5" 30.0	114'-10" 35.0	131'-3" 40.0	147'-8" 45.0	164'-0" 50.0	180'-5" 55.0	196'-10" 60.0	213'-3" 65.0	229'-8" 70.0	246'-1" 76.0	262'-6" 80.0
L9	262'-6" 80.0	86'-1" 26.25 m	45'-3" 13.79 m	69224 31.4	58862 26.7	50882 23.1	44533 20.2	35494 16.1	32760 14.9	30247 13.7	25243 11.4	21495 9.75	18607 8.44	16314 7.40	14440 6.55	12875 5.84	11552 5.24	10428 4.73	9458 4.29	8598 3.90
L8	246'-1" 75.0	87'-8" 26.72 m	46'-7" 14.20 m	70547 32.0	61067 27.7	52822 24.0	46296 21.0	36817 16.7	33422 15.2	30864 14.0	25772 11.7	21980 9.97	19026 8.63	16689 7.57	14771 6.70	13183 5.98	11839 5.37	10692 4.85	9700 4.40	
L7	229'-10" 70.0	102'-4" 31.18 m	53'-0" 16.15 m	70547 32.0	70547 32.0	61883 28.1	54453 24.7	43851 19.8	35979 16.3	35273 16.0	30886 14.0	26423 11.99	22994 10.43	20260 9.19	18011 8.17	16138 7.32	14572 6.61	13228 6.00		
L6	213'-3" 65.0	106'-11" 32.58 m	56'-3" 17.15 m	70547 32.0	70547 32.0	66578 30.2	58542 26.6	46958 21.3	38911 17.7	35714 16.2	32498 14.7	27844 12.63	24250 11.00	21362 9.69	19026 8.63	17086 7.75	15432 7.00			
L5	196'-10" 60.0	114'-1/2" 34.76 m	60'-1" 18.31 m	70547 32.0	70547 32.0	70547 32.0	63492 28.8	50928 23.1	42306 19.2	38867 17.6	34987 15.9	30026 13.62	26168 11.87	23104 10.48	20591 9.34	18519 8.40				
L4	180'-5" 55.0	120'-7" 36.75 m	63'-0" 19.20 m	70547 32.0	70547 32.0	70547 32.0	67240 30.5	54012 24.5	44907 20.4	41292 18.7	35273 16.0	32011 14.52	27954 12.68	24691 11.20	22046 10.00					
L3	164'-1" 50.0	121'-5/2" 37.02 m	64'-0" 19.01 m	70547 32.0	70547 32.0	70547 32.0	68563 31.1	55115 25.0	45833 20.8	42152 19.1	35273 16.0	32297 14.65	28175 12.78	24912 11.30						
L2	147'-8" 45.0	123'-3" 37.56 m	65'-7" 20.00 m	70547 32.0	70547 32.0	70547 32.0	70547 32.0	56878 25.8	47266 21.4	43496 19.7	35935 16.3	32826 14.89	28660 13.00							
L1	131'-3" 40.0	124'-0" 37.80 m	86'-10" 20.37 m	70547 32.0	70547 32.0	70547 32.0	70547 32.0	57981 26.3	48347 21.9	44489 20.2	36816 16.7	35273 16.00								

PEINER SK 575 Speeds and Counterweight

Speeds









FU 9-320/4		v = 0 → ~260 fpm (80 m / min.)																			1 x 12.2 HP 1 x 9.0 kW	
SR 10-190/4		v = 0 → ~120 fpm (36 m / min.)																				4 x 12.2 HP 4 x 9.0 kW
K WB 120/4		v = 0 → 0.9 min ⁻¹ (rpm)																				L1 - L4 2 x 11.4 HP 2 x 8.4 kW L5 - L9 3 x 11.4 HP 3 x 8.4 kW
 HK max. = 720' / 220 m 5-Layers																						
Type SR WB 102-160/4F ~160 HP (120.0 kW)			2-Part Line	▶ 490 fpm 150 m/min	7700 lbs 3500 kg	4-Part Line	▶ 245 fpm 75 m/min	15,400 lbs 7000 kg	Total motor output without SR 10-190/4 ~ 200 HP ~ 150 kW													
			▶ 315 fpm 96 m/min	13,200 lbs 6000 kg		▶ 158 fpm 48 m/min	26,400 lbs 12 000 kg															
			▶ 195 fpm 60 m/min	22,000 lbs 10 000 kg		▶ 98 fpm 30 m/min	44,000 lbs 20 000 kg															
			▶ 125 fpm 38 m/min	35,300 lbs 16 000 kg		▶ 63 fpm 19 m/min	70,600 lbs 32 000 kg															
Connected power 170 kVA																						

Counterweight

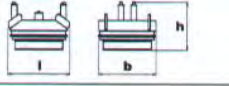
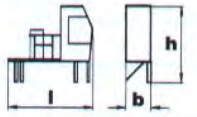
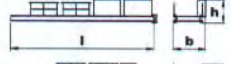
Jib	L1	L2	L3	L4	L5	L6	L7	L8	L9
Counterweight BG	50,800 lbs 23 150 kg	54,400 lbs 24 800 kg	57,600 lbs 26 250 kg	61,200 lbs 27 900 kg	68,000 lbs 31 000 kg	64,400 lbs 29 350 kg	68,000 lbs 31 000 kg	64,400 lbs 29 350 kg	68,000 lbs 31 000 kg
	1 x 3200 lbs 1 x 1450 kg		1 x 3200 lbs 1 x 1450 kg			1 x 3200 lbs 1 x 1450 kg		1 x 3200 lbs 1 x 1450 kg	
	7 x 6800 lbs 7 x 3100 kg	8 x 6800 lbs 8 x 3100 kg	8 x 6800 lbs 8 x 3100 kg	9 x 6800 lbs 9 x 3100 kg	10 x 6800 lbs 10 x 3100 kg	9 x 6800 lbs 9 x 3100 kg	10 x 6800 lbs 10 x 3100 kg	9 x 6800 lbs 9 x 3100 kg	10 x 6800 10 x 3100 kg

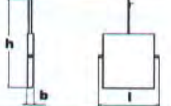
PEINER SK 575 Dimensions and transport weights

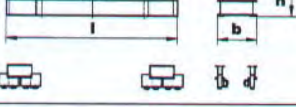
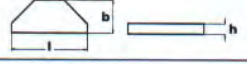
See operating manual for mounting weights

	Designation		Dimensions (ft / m)			Weight lbs / t
			l	b	h	
1	Jib		39'-0" 11.89	6'-6" 1.97	6'-11" 2.12	7490 3.40
	Section II		40'-6" 12.34	6'-6" 1.97	7'-3" 2.21	8860 4.02
	Section III		38'-10" 11.84	6'-6" 1.97	7'-7" 2.30	5420 2.46
	Section IV		18'-8" 5.69	6'-6" 1.97	6'-10" 2.09	5360 2.43
	Section V		35'-0" 10.68	6'-6" 1.97	6'-11" 2.11	5200 2.36
	Section VI		35'-5" 10.79	6'-6" 1.97	6'-4" 1.93	4280 1.94
	Section VII		33'-6" 10.20	6'-6" 1.97	6'-3" 1.90	2760 1.25
	Section VIII		33'-5" 10.19	6'-6" 1.97	6'-2" 1.88	1700 0.77
	Jib Tip		6'-8" 2.02	4'-6" 1.37	2'-11" .88	660 0.30
	2		Tower Top cpl.		27'-1" 8.26	6'-5" 1.96
3	Turntable cpl.		11'-9" 3.58	7'-1" 2.17	7'-5" 2.27	24,100 10.93
4	Cab Support, railing, electrical panel		5'-5" 1.65	3'-7" 1.10	7'-2" 2.18	1040 0.47
			11'-8" 3.55	6'-7" 2.00	6'-5" 1.95	2050 0.93
5	Counterjib G 2 G 1	 	38'-10" 11.85	7'-5" 2.25	5'-11" 1.80	7500 3.40
			31'-1" 9.48	6'-8" 2.03	5'-8" 1.72	6030 2.74
6	Counterjib ballast BG		5'-11" 1.81	0'-8" 0.19	10'-4" 3.14	3200 1.45
			5'-11" 1.81	0'-8" 0.19	15'-4" 4.68	6800 3.10
7	Tower section TS 213.1 TSV 213	 	19'-6" 5.95	7'-10" 2.39	7'-10" 2.38	9790 4.44
			39'-4" 12.00	10'-4" 3.15	10'-4" 3.15	31,090 14.10
8	Rail mounted undercarriage with electrical panel		44'-0" 13.40	9'-6" 2.90	3'-9" 1.15	38,440 17.10
			8'-2" 2.50	2'-8" 0.82	2'-11" 0.89	
9	Central ballast block BZ		13'-5" 4.50	6'-1" 2.05	1'-2" 0.40	14,550 6.60
10	Foundation block BF		9'-0" 3.00	3'-7" 1.20	2'-6" 0.75	14,550 6.60
11	Accessories	